

## Switch 18" Retrofit Shower System with 16" Shower Arm

F9516

### Specifications:

- Metal construction
- Designed to work in a new installation or to retrofit an existing installed shower arm
- Retro-fit slide rail features integral 2-way diverter to direct water between the hand shower and shower head
- Features a swivel 16" Shower arm that has a 6" rise above the water inlet and is designed for a rain shower
- When used for a retrofit, slide rail is intended to work with existing rough-in plumbing. Valves and valve covers are not included, but can be purchased separately
- Can be installed either by drilling into shower wall or a drill-free methose with waterproof glue.
- Switch can also work with an installed diverter tub spout, so a non-diverting pressure balancing valve can deliver water to a tub, shower and hand shower.
- Large 65 mm escutcheons are available if needed in a retrofit situation to cover larger holes in the finished wall, (sold separately).

### Components:

- FP900216..... 16" Switch Shower Arm
- FP933002..... Switch 18" Main Shower Body

### Features:



Retrofit Kit



Speed Connect



Polished Chrome (CP), Brushed Nickel (BN) and Matte Black (MB)

F9516 June 2024



## Technical Drawing

F9516

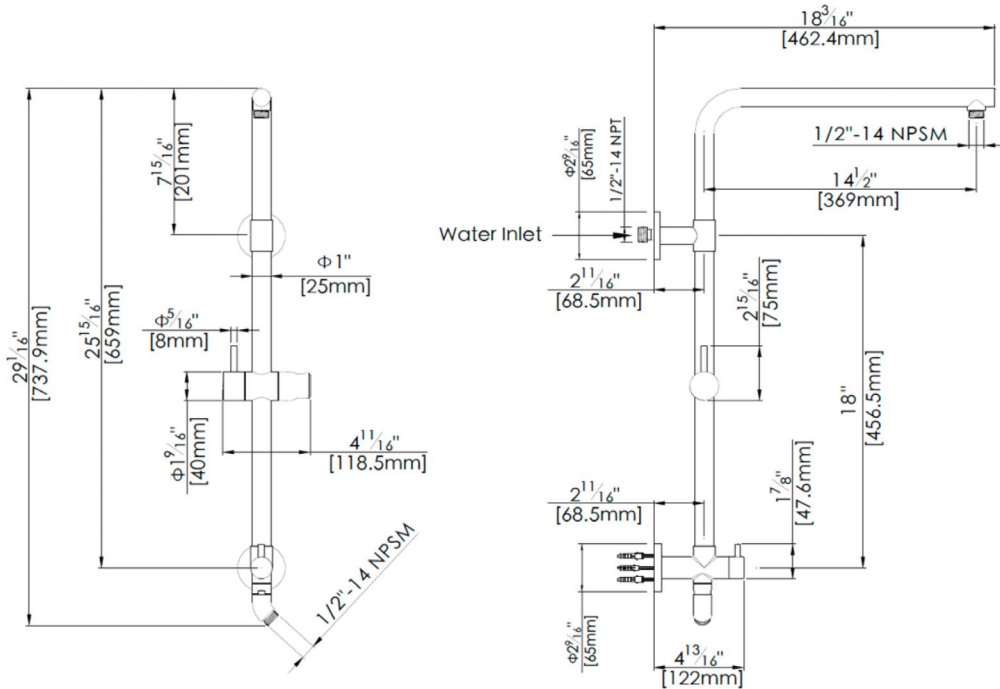

**Codes and Standards:** ANSI/ASME A112.18.1, CSA B125.1, IAPMO /cUPC Listed, EPA Watersense Listed

### Warranty:

Limited Lifetime Faucet Warranty against material and manufacturing defects for residential use.  
2 Year Limited Warranty on all industrial, commercial and business applications.

### Codes & Standards:

ANSI/ASME A112.18.1  
CSA B125.1  
IAPMO /cUPC Listed  
EPA Watersense Listed

### Flow Rate:

N/A - dependant on shower components chosen