

Caravelle Smart Back Outlet Two Piece

Easy Height & Elongated 4.8/3L Washdown Suite

Bowl: **#920450W** Left Lever Tank: **#920101W**

Right Lever: **#920101W-R**



Plumbers Installation Instructions:

PLEASE READ CAREFULLY BEFORE INSTALLATION.

IMPORTANT:

Do not use a wax ring with a reducing horn on this toilet as it reduces the flushing efficiency. Use a proper foam gasket or wax ring designed for back outlet toilet installation.

Working Water Pressure:

USA & Canada: Recommended working water pressure is 20-80psi (140-550Kpa).

Closet Bowl Fixing Procedure:

1. It is important for installation of the Caravelle Smart Back Outlet Two Piece Washdown toilet that the closet flange be accurately set out on the finished wall as detailed in **Fig.2**.
2. Position closet bolts and foam gasket or wax ring (not supplied) onto closet flange, as detailed in **Fig.3**.
3. Position back outlet connector, (M-147380), onto closet bolts and secure onto foam gasket or wax ring with nuts as detailed in **Fig. 4**.
4. Attach back plate onto the finished wall with the supplied plastic anchor and bolts, or attached double sided tape, as shown in **Fig.4**. Attach supplied nuts and washers to metal support rod, screw rod into centre of plate and snap it into the holder at the top of connector. Tighten one nut and washer on either side of the holder to hold securely.
5. Drill two 10mm diameter holes into the floor and push the supplied plastic anchors into the holes as detailed in **Fig.5**.
6. Secure the bowl fixing bracket onto the floor with the supplied hex head screw and washer, as shown in **Fig.5**.
7. Ensure that the area around the closet bowl is clean and free from building materials.
8. Apply a soap and water solution as a lubricant to the back outlet connector rubber seal. Slide bowl into position.
9. Slide the closet bowl over the back outlet connector to the finished wall.
10. Insert the plastic bushings and brass bushings into the bowl fixing hole as shown in **Fig. 6**. Insert the stainless steel screws through the bushings and tighten into the bowl fixing bracket. Cover with the supplied caps.
11. It is recommended that a bead of silicone caulking is applied fully around base of the closet bowl, leaving 1-2" at the rear of the bowl. Remove any excess silicone caulking.

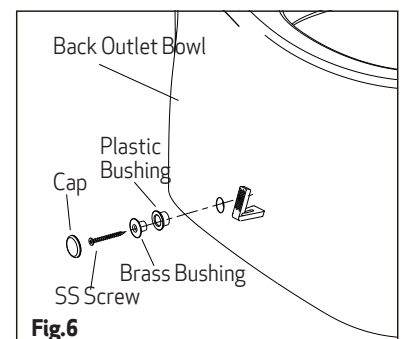
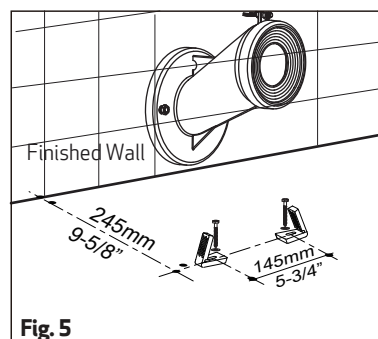
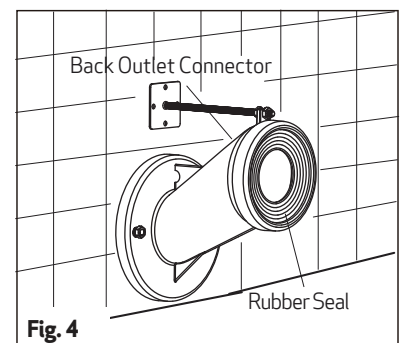
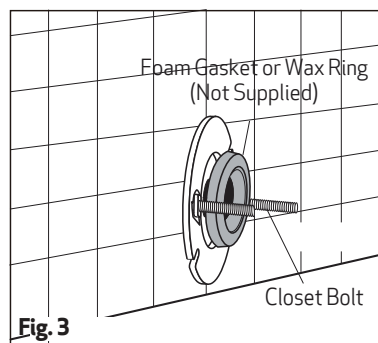
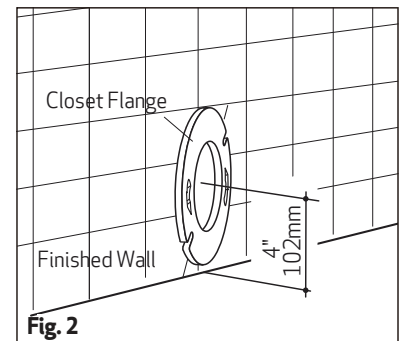
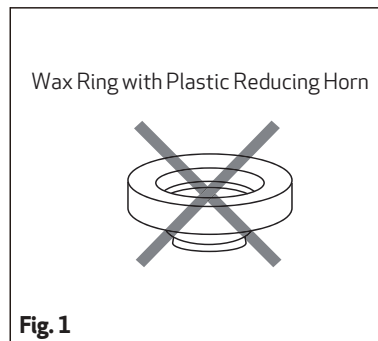
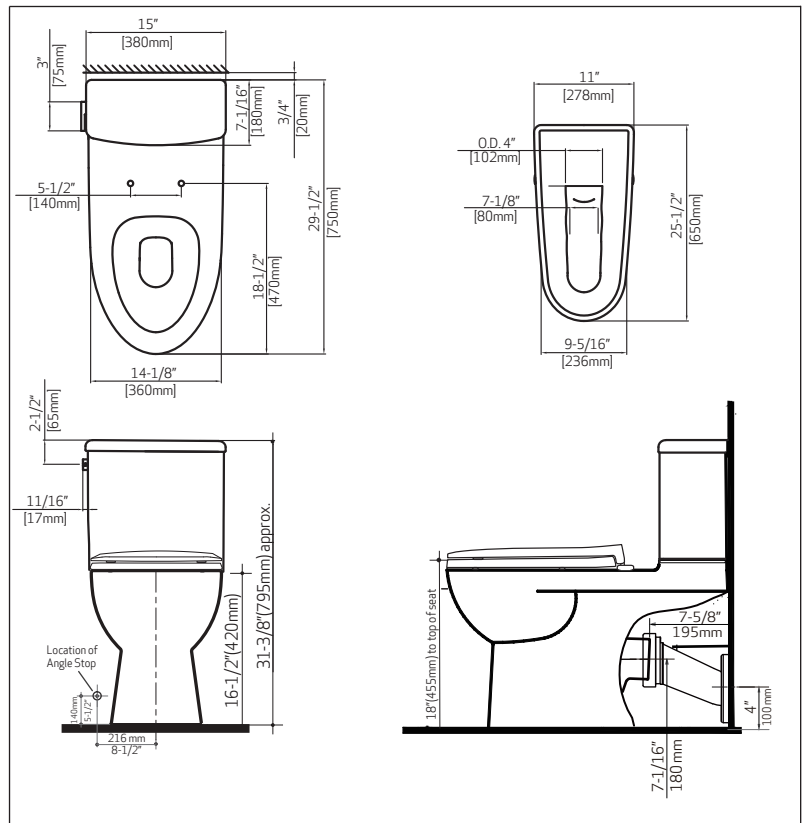

Caravelle Smart Back Outlet

4.8/3L Easy Height, Elongated Dual Flush Washdown Suite

Bowl: **920450W** Tank: **920101W / 920101W-R**

Tank Fixing Procedure:

1. Determine the type of water supply connection to be used. Braided supply lines can simply be attached to the inlet valve connection. If a 3/8" hard tube/pipe connection is being used, a tapered rubber seal and wing nut assembly is included.
2. Ensure that the foam seal is fitted onto the tail piece on the underside of the tank as detailed in Fig. 7.
3. Lower tank onto closet bowl, allowing the two tank fixing bolts protruding below the tank to fit through the corresponding holes in the bowl.
4. Fit the supplied plastic wing nuts onto the tank fixing bolts that are protruding through the bowl and gradually tighten the left and right wing nuts by hand to evenly secure tank to bowl.
5. Connect water supply and check connections for any leaks.
6. Install the toilet seat according to the instructions included with the seat.
7. Fit the tank lid onto the top of tank.

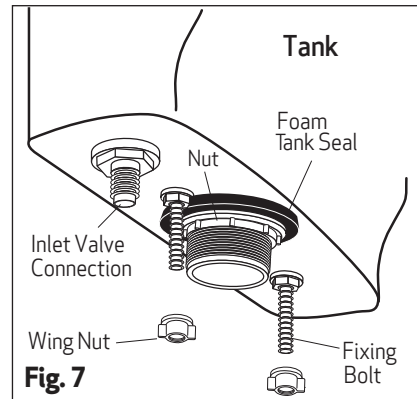

All measurements are subject to accepted manufacturing tolerances. The manufacturer reserves the right to change specifications at any time without giving prior notification. The product should be installed by a qualified plumber. Local authority, Water Board, and Building Regulations may apply to the installation of this product, and you should consult the appropriate bodies on these requirements. Failure to comply may invalidate the product warranty.

Tank Spare Parts

Inlet Valve Replacement Parts

A1280-REPAIRKIT

Code	Part Description
A1280-REPAIRKIT	Rubber Seal Kit
A1280	Inlet Valve

Outlet Valve Replacement Parts

A242330200 / A2423330200-R

ARA2419001

Code	Part Description
ARA2419001	Outlet Valve Diaphragm Seal
A24233	Outlet Valve
A2423330200	Left Handle Lever
A2423330200-R	Right Handle Lever

CLEANING INSTRUCTIONS FOR VITREOUS CHINA:

To preserve the glazed surface, this toilet should be cleaned only with a mild household detergent or warm soapy water. Do not use any abrasive cleaners in the tank or bowl as this can damage the glazing. Use of in tank cleaners or bleach tablets may void warranty.

For spare parts contact:

Sustainable Solutions

Under license from Caroma Industries Limited, Australia
Manufactured by Sustainable Solutions

Vancouver, BC, Canada + Ferndale, WA, USA
Telephone: (604) 430.2020
Toll Free: (800) 460.7019
help@sustainable-solutions.com
www.caromausa.com www.sustainable-solutions.com



ULTRA HIGH EFFICIENCY TOILET
UHET

