

### SPECIFICATIONS

Customer Service: 1-800-460-7019  
www.fluidfaucets.com

#### Specifications

- Metal construction for durability and reliability
- Pressure balancing volume control
- Max-temperature limit stop for added safety
- Integral stop check valves for easy maintenance
- Requires pressure balancing valve F1002B or F1002B-PEX or F1002B-PEX-W
- Valve and trim packages are sold separately

#### Finish

- CP (Polished Chrome)
- BN (PVD Brushed Nickel)
- MB (Matte Black)

#### Codes and Standards

- ANSI/ASME A112.18.1
- CSA B125.1
- IAPMO / cUPC

#### Warranty

- Limited Lifetime Faucet Warranty against material and manufacturing defects for residential use.
- 2 Year Limited Warranty on all industrial, commercial and business applications.

## fluid Oceanside Square Trim Kit for Pressure Balancing In-Wall Valve

### Model: FP6023332-2PS

Includes:

- |               |                     |
|---------------|---------------------|
| F1001T        | Sleeve Tube and Cap |
| FP6001033-2PS | Square Cover Plate  |
| FP6023041     | Oceanside Handle    |



#### FP6023332-2PS

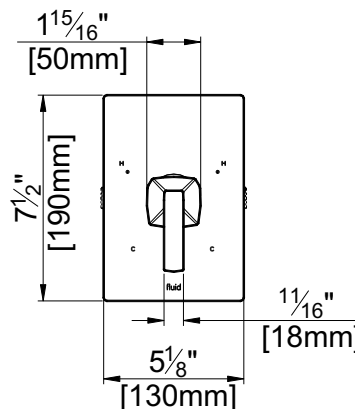
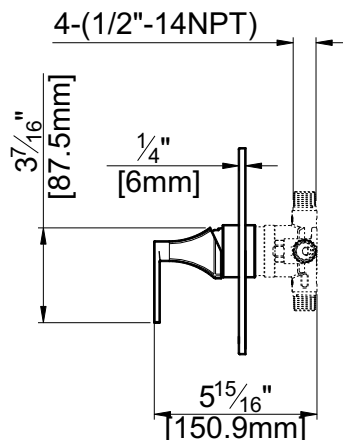

#### F1002B

