

### Specifications

- Heavy brass forged body construction
- Pressure balancing with built-in 2-way diverter ceramic cartridge that ensures anti-scald operation with lifelong trouble free service
- Built-in anti-back flow device prevents cross flow
- Single lever handle operation allows flow diverting and temperature control
- Integral stop valves for easy maintenance
- Three inlet connection options: 1/2" CxC soldering & 1/2" NPT thread or PEX or PEX-W
- Adjustable installation depth from 2-3/8" (60mm) to 3-1/8" (80mm)
- Enables back-to-back installation
- Bubble level is provided for easy and accurate installation.
- Mud guard is provided to protect trim finish
- A wide selection of complimenting trims are available and sold separately

### Flow Rate

- 4.5 gpm @ 60 psig

### Finish

- Brass

### Codes and Standards

- ANSI/ASME A112.18.1
- CSA B125.1
- IAPMO / cUPC Listed

### Warranty

- Limited Lifetime Faucet Warranty against material an manufacturing defects for residential use.
- 2 Year Limited Warranty on all industrial, commercial and business applications.

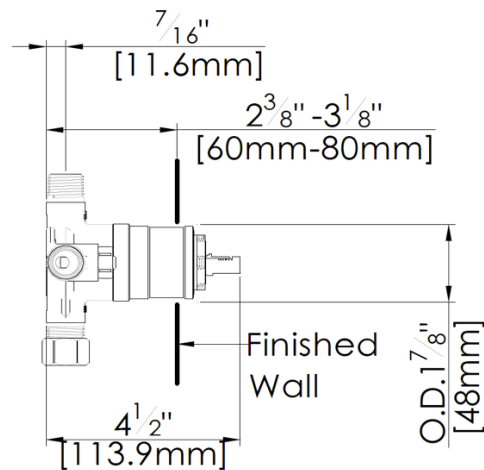
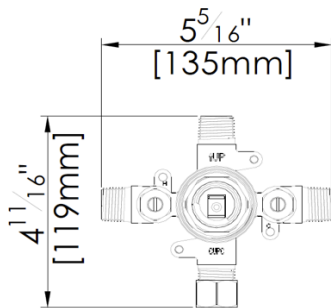

### fluid Pressure Balancing Valve with Built-in 2 Way Diverter

Model: F1002B

F1002B-PEX

F1002B-PEX-W

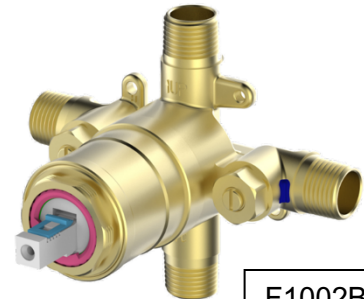

F1002B

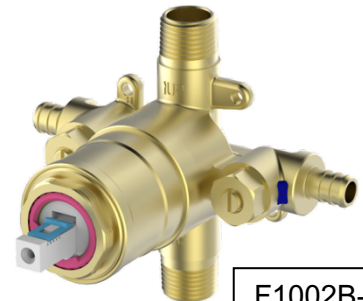

F1002B-PEX